

The reduced order model of a proton-conducting solid oxide fuel cell

Arkadiusz Szczęśniak*, Jarosław Milewski

*Institute of Heat Engineering, Warsaw University of Technology
21/25 Nowowiejska Street, 00–665 Warsaw, Poland*

Abstract

Solid Oxide Fuel Cells are regarded as a high-efficiency, low-environmental impact technology for power and heat generation. SOFCs based on proton-conducting electrolyte are one of the most attractive technologies, mainly due to their high efficiency in energy conversion and operation at the intermediate range of temperatures. The main objective of this paper is an investigation into the possibility of applying the reduced order model proposed by Milewski [1] to model proton-conducting Solid Oxide Fuel Cells. The reliability of the simulation results were verified with experimental data reported in the literature. It was shown that the reduced order model is valid for both ion-conducting SOFCs and proton-conducting SOFCs.

Keywords: Fuel cells, Proton-conducting SOFC, Numerical modeling

1. Introduction

Solid Oxide Fuel Cells (SOFCs) are regarded as a high-efficiency, low-environmental impact technology for power and heat generation. SOFCs are based on the concept of direct conversion of fuel chemical energy into electricity through an electrochemical process. But the low reliability and durability of SOFCs, directly linked with the high operating temperature (ca. 800...1000°C), restrict the practical application and commercialization of SOFCs.

Extensive research studies have been conducted into developing proton-conducting materials which are able to operate at an intermediate range of temperatures. The available literature reports several analyses of proton-conducting Solid Oxide Fuel Cells performances, adopting various approaches

and models. In general, there are two types of approach for SOFC modeling.

The first focuses on detailed analysis of fuel cell working mechanics (e.g. electrochemical reaction kinetics, gas transport) [2–4]. For instance Ni [5] reported a detailed electrochemical model of a proton-conducting SOFC, which includes analysis of overpotential concentrations on the anode and cathode side.

The second approach called “the reduced order model” in a simplified way allows one to determine the key fuel cell parameters, from the power engineer’s point of view (e.g. power output, fuel consumption) [1]. This second approach provides power engineers with a simplified model having sufficient accuracy to investigate the fuel cell’s behavior after integration with power machines.

Due to the fact that research indicates that SOFCs based on proton-conducting electrolyte is a promising technology, with interesting advantages over their SOFC ion-conducting counterparts, mainly be-

*Corresponding author

Email addresses:

arkadiusz.szczesniak@itc.pw.edu.pl (Arkadiusz Szczęśniak*), milewski@itc.pw.edu.pl (Jarosław Milewski)

cause of their operating at an intermediate range of temperatures and with greater energy conversion efficiency than classical SOFCs [6–8]. In addition, Ni [7] performed a thermodynamics comparison between proton-conducting and ion-conducting SOFCs, which are fed by ammonia. This analysis indicates that a proton-conducting SOFC has higher theoretical maximum efficiency than a classical SOFC.

Therefore, the aim of this analysis is to investigate the possibility to apply the reduced order model approach, which gave satisfactory agreement with classical SOFC operation, to proton-conducting fuel cells.

Furthermore, studies were carried out at the University of St. Andrews to discover electrolyte materials with sufficient proton-conducting properties in the temperature range of 150...400°C [9].

2. Theory

The principle of proton-conducting SOFC operation is similar to classical solid oxide fuel cells.

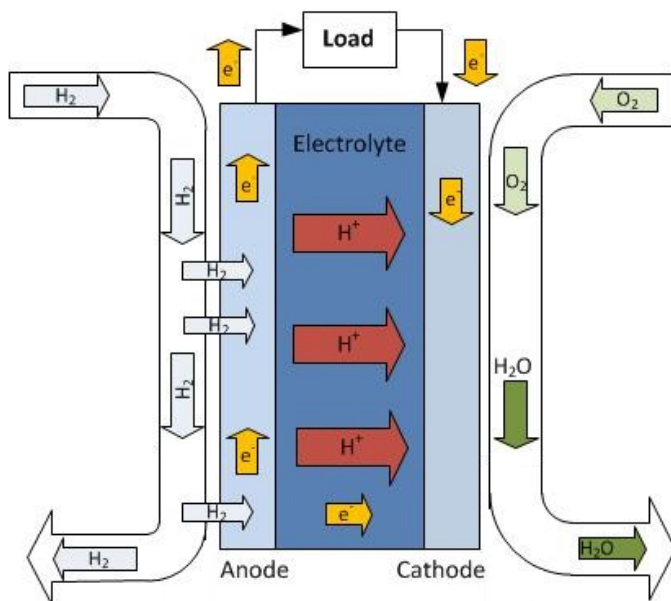
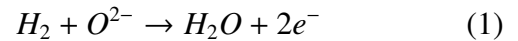

Figure 1: Schematic of a proton-conducting SOFC

However, in the proton-conducting SOFC (see Fig. 1) hydrogen molecules are oxidized into protons and electrons at the anode side. The electrons flow through external wire from the anode to the cathode, forming direct-current electricity. At the same time,

protons are conducted through the electrolyte to the cathode/electrolyte side, where the O_2 is delivered and reacts with H^+ and e^- to form water vapor (Eq. 1 and Eq. 2). Then, the water vapor leaves the fuel cell at the cathode surface. Both global electrochemical reactions at the anode and cathode can be written as follows:

reaction at the anode-electrolyte side



reaction at the anode-electrolyte side

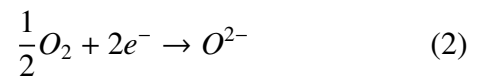

The generation of water vapor at the cathode side increases the hydrogen partial pressure. Therefore, the overall system efficiency increases with respect to the classical SOFC. The main advantage of electrolyte made with proton-conducting material is the high ionic conductivity at an intermediate range of temperatures (sufficient performances are reported in the literature at 600...700°C [10]). The most popular type of material for solid state proton conductors are perovskite-type oxides structures which, in the presence of a wet atmosphere and elevated temperatures, exhibit high protonic conductivity [11].

3. Model development

The singular cell of the SOFC is composed of three main layer “elements”: anode, cathode and solid electrolyte. Other elements the SOFC module includes (e.g., electrode assemblies, gas manifolds) are not taken into account in this simulation, because there are not regarded as singular cell components [1].

The SOFC simulator was created using Aspen Hysys software, which accurately predicts thermodynamic properties of reactions occurring on the anode and cathode sides of fuel cells.

The maximum (ideal) voltage the fuel cell can theoretically achieve if there were no losses, depends on the hydrogen partial pressures at the anode and cathode side, as well as, the fuel cell operating temperature, and is expressed by the Nerst equation:

$$E_{\max} = \frac{RT}{2F} \ln \frac{p_{H_2, \text{anode}}}{p_{H_2, \text{cathode}}} \quad (3)$$

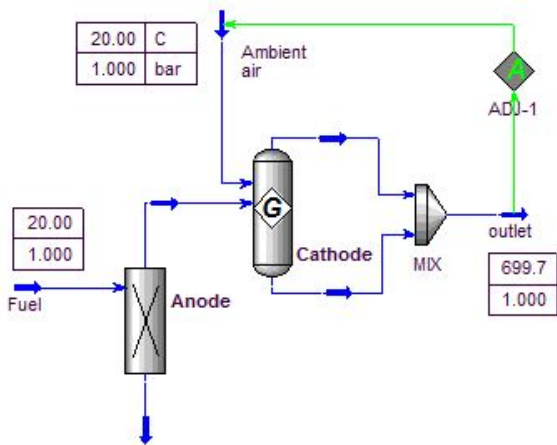

Figure 2: SOFC simulator in Aspen Hysys

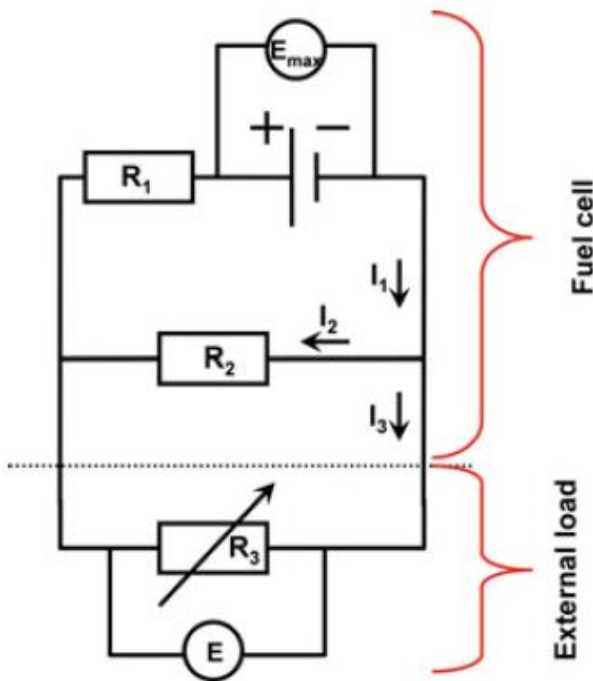

Figure 3: Fuel cell equivalent electric circuit [1]

In Fig. 3 the resistances r_1 and r_2 stands for fuel cell ionic resistance and electrical resistance, respectively. The r_3 resistance denotes the external load resistance. On the basis of this electric circuit, Milewski [1] derived the equation of fuel cell voltage, using Ohm’s and Kirchoff’s law as well as electrical dependence on fuel flow. Therefore, the volt-

age generated by the fuel cell can be expressed as follows:

$$E_{SOFC} = \frac{E_{max} - r_1 \cdot \eta_{H2} \cdot i_{max}}{\frac{r_1}{r_2} \cdot (1 - \eta_{H2}) + 1} \quad (4)$$

The maximum current density (i_{max}) which can theoretically be drawn from the cell, can be expressed by the relationship:

$$i_{max} = \frac{2 \cdot F \cdot n_{H2,equivalent}}{A} \quad (5)$$

In other words, the value of i_{max} denotes the maximum current which can be drawn from the singular centimeter of the fuel cell if all of the fuel is utilized, for a given fuel.

3.1. Estimation of model parameters

Due to insufficient data reported by Sun [4] concerning the conductivity factors of particular electrodes, the area specific ionic resistance (r_1) and electrical resistance were estimated on the basis of the available experimental results.

In order to estimate the dependence of these model parameters on temperature, the model was validated with experimental data at different temperatures (700°C, 650°C, 600°C and 550°C) and the new values of those parameters were calculated.

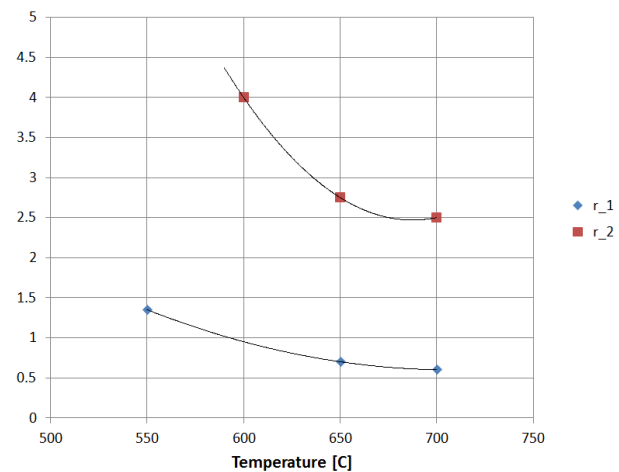

Figure 4: Estimation of model parameters’ dependence on temperature

Thus, on the basis of Fig. 4, the equations for the area specific ionic resistance and electronic resistance were approximated to the following relations:

$$r_1 = 0.0003 \cdot T^2 - 0.0425 \cdot T + 15.65 \quad (6)$$

$$r_2 = 0.002 \cdot T^2 - 0.275 \cdot T + 97 \quad (7)$$

However, because r_1 and r_2 depend not only on temperature, but also on fuel cell thickness and material properties [1], the above equations (Eq. 4 and Eq. 5) are valid only for this particular material and fuel cell thickness.

3.2. Model validation

The numerical model of a proton-conducting SOFC was verified with experimental data reported in the literature by Sun [4]. The anode, electrolyte, cathode of the fuel cell described in this experiment are made with NiO-BZCY, BZCY and SSC-SDC, respectively. The electrochemical performance of the fuel cell was tested in a home-made cell testing system at a temperature range of 550–700°C by a DC Electronic Load (ITech Electronics model IT8511). The hydrogen was fed to the anode chamber at flow rate 25 ml min⁻¹(STP), while the cathode was exposed to static air.

Table 1: Values of input parameters used in model validation

	Parameter	Value	Unit
1.	Hydrogen flow rate	25	ml min ⁻¹ (STP)
2.	Fuel cell area	0.23	cm ²
3.	Pressure at anode side	1	bar
4.	Pressure at cathode side	1	bar

Table 1 presents input parameters which were used to validate a mathematical model of the Solid Oxide Fuel Cell.

The simulation showed sufficient agreement with experimental data (Fig. 5). However, due to the approximation of parameters r_1 and r_2 , this model is not able to investigate how the thickness of the electrolytes affects cell performance. Despite this drawback, the SOFC simulator is able to examine the influence of key parameters on fuel cell performance, due to the

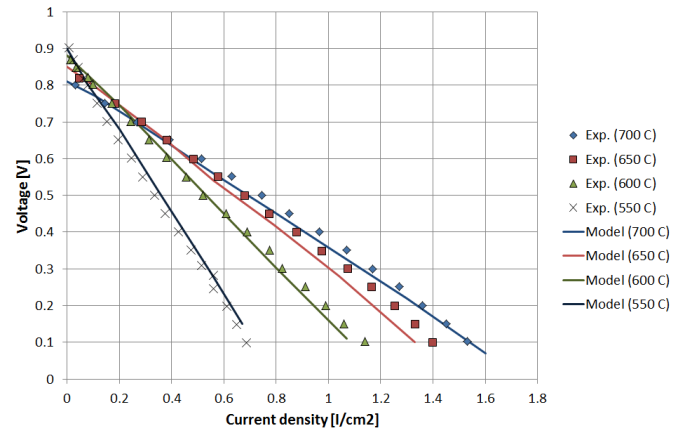

Figure 5: Experimental data reported by Sun [4] and modeling results

fact that all important parameters have physical explanations, thus, they can be varied over practically achieved ranges.

4. Results

The validated numerical model was used to investigate the correctness of model behavior with respect to changing operating conditions (temperature and pressure).

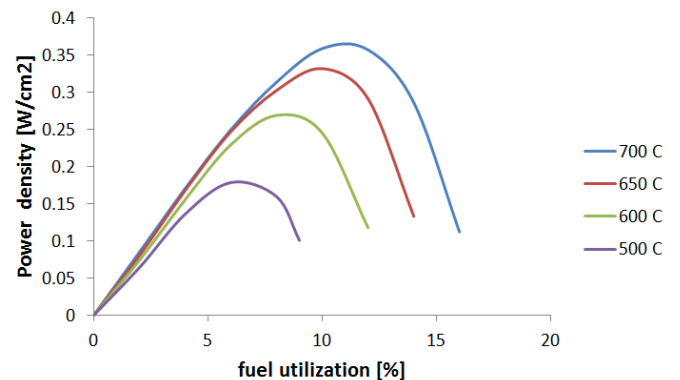

Figure 6: Fuel cell performance at different operating temperatures

Firstly, the influence of operating temperature on the power generated by the fuel cell was analysed. The investigated range of temperatures corresponds to the electrolyte's possibility to operate at a given temperature.

Fig. 6 shows that the lower the operating temperature, the higher the maximum voltage generated by the cell. This could be caused by the fact that, with

a drop in temperature, the partial pressure of hydrogen at the cathode side decreases as well. Therefore, the theoretical maximum voltage increases, because the difference between hydrogen partial pressures at the cathode and anode increases.

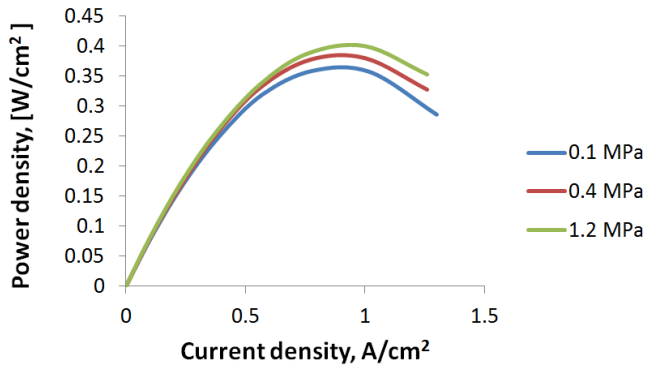

Figure 7: The influence of operating pressure on SOFC performance

Additionally, the influence of operating pressure on fuel cell performance was examined (see Fig. 7). According to the numerical simulation, the increase in operating pressure is able to slightly boost the performance of the fuel cell. This is could be caused by the fact that O_2 is able to diffuse to the electrode/electrolyte interface more easily when the operating pressure is higher [2].

The results presented above indicate that the power output changes in a way that is well-known and described in the literature.

Interestingly, the above phenomenon and the intermediate operating pressure (700°C) of the SOFC open up a path for implementation of a hybrid system based on a SOFC to increase overall system efficiency through the utilization of high quality waste heat.

5. Discussion

Proton-conducting Solid Oxide Fuel Cells are regarded as a technology that will bridge the gap between Proton Exchange Membrane Fuel Cells (PEMFCs) and classical SOFCs, due to their lower operating temperatures and extended working life. Therefore, one possibly key issue with a view to successfully integrating SOFCs with power machines

could be the creation of a reliable simulator to provide accurate predictions of SOFC performance under different operating conditions as well as with other power machines.

In the literature, various approaches of SOFC modeling are reported. In this paper, a simplified approach was verified to apply to proton-conducting SOFC. This reduced order approach allows power engineers in a simplified form to determine fuel cell performance with sufficient agreement. This tool enables power engineers to investigate SOFC performance in integration with thermodynamics cycles, mainly due to the fact that all parameters used in the simulation process have their own physical explanations and changing one does not require the others to be updated.

6. Summary

Solid Oxide Fuel Cells are identified as a high-efficiency and low-environmental impact technology for power and heat generation. The benefits include high efficiency, low emission of pollutants and silent operation (no moving parts). In general, there are two types of electrolyte possible for use in a SOFC: proton-conducting and ion-conducting electrolyte.

Proton-conducting SOFCs have several interesting advantages over classical SOFCs, particularly in terms of lower operating temperature and higher efficiency. Therefore, SOFCs based on proton-conducting electrolyte are expected to play an important role in clean power generation in the coming decades.

In this paper, the reduced order model approach of a proton-conducting SOFC is presented. The governing equations of the model are described. The model was constructed in accordance with an approach described by Milewski [1]. The developed mathematical model was verified with experimental data.

In addition, the model behavior was verified with respect to changing operating conditions. The change of key model parameters corresponds to behavior that is well-known and described in the literature.

The presented model produced by the Milewski approach [1] turns out to be valid not only for high

temperature ion-conducting SOFCs, but also for intermediate temperature proton-conducting SOFCs.

References

- [1] J. Milewski, K. Świrski, M. Santarelli, P. Leone, Advanced Methods of Solid Oxide Fuel Cell Modeling, 1st Edition, Springer-Verlag London Ltd., 2011.
- [2] Y. Patchravorachot, N. Brandon, W. Paengjuntek, S. Assabumrungrat, A. Arpomwichanop, Analysis of planar solid oxide fuel cells based on proton conducting electrolyte, Solid State Ionics 181 (2012) 1568–1576.
- [3] M. Bavarion, M. Soroush, Mathematical modeling and steady-state analysis of a proton-conducting solid oxide fuel cell, Journal of Process Control 22 (2012) 1521–1530.
- [4] W. Sun, Y. Wang, S. Fang, Z. Zhu, L. Yan, W. Liu, Evaluation of $\text{BaZr}_{0.7}\text{Y}_{0.2}$ based proton-conducting solid oxide fuel cells fabricated by a one step co-firing process, Electrochimica Acta 56 (2011) 1147–1454.
- [5] M. Ni, M. Leung, D. Leung, Mathematical modelling of proton-conducting solid oxide fuel cells and comparison with oxygen-ion conducting counterpart, Fuel Cells 7 (2007) 269–278.
- [6] L. Bi, E. Fabbri, E. Traversa, Effect of anode functional layer on the performance of proton-conducting solid oxide fuel cells, Electrochemistry Communications 16 (2012) 37–40.
- [7] M. Ni, Y. Leung, M. Leung, Thermodynamic analysis of ammonia fed solid oxide fuel cells: Comparison between proton-conducting electrolyte and oxygen ion-conducting electrolyte, Journal of Power Sources 183 (2008) 682–686.
- [8] A. Demin, P. Tsiakarak, Thermodynamic analysis of a hydrogen fed solid oxide fuel cell based on a proton conductor, International Journal of Hydrogen Energy 26 (2001) 1103–1108.
- [9] S. Saxin, J. Irvine, Bridging the PEMFC-SOFC gap, development of a novel low-intermediate temperature solid proton conductor (2012).
- [10] F. Lefebvre-Joud, G. Gauthier, J. Mougins, Current status of proton-conducting solid oxide fuel cells development, J Appl Electrochem 39 (2009) 535–543.
- [11] R. Hariharan, T. Prasanna, P. Gopalan, Novel perovskite based proton conductor for solid oxide fuel cells, Scripta Materialia 66 (2012) 658–661.

Nomenclature

η_{H_2}	hydrogen utilization factor
A	active area
E_{max}	maximum cell voltage, V

E_{SOFC}	cell voltage, V
F	Faraday constant, C/mol
i_{max}	maximum current density, A/cm ²
n_{H_2}	hydrogen molar flow, mole/s
$p_{H_2,an}$	hydrogen partial pressure at anode side
$p_{H_2,cat}$	hydrogen partial pressure at cathode side
R	universal gas constant, J/mol/K
r_1	area specific ionic resistance, cm ² /S
r_2	area specific electrical resistance
T	temperature, °C
T	temperature, K