

# Analysis, Simulation and Hardware Implementation of Single Switch Power Amplifier for Active Magnetic Bearing (AMB) system

Sukanta Debnath<sup>1✉</sup>, Pabitra Kumar Biswas<sup>1</sup>, and Jonathan Laldingliana<sup>1</sup>

<sup>1</sup>NIT Mizoram, India  
✉sukanta.eee@nitmz.ac.in

## Abstract

Active Magnetic Bearing is the advancement of habitual technology and is used to increase the rotational speed. AMB is using power electronics drives, which is the key features of this technology. In this paper, a simple and cheap converter with reduced switch is simulated and implemented in hardware for the validation of simulation result is presented. The principle of the active magnetic bearing and power amplifier is introduced and the generation of pulse is also described. Then, result of simulation and hardware output is compared. Based on the output of hardware setup simulation result is validated. With the help of this amplifier cheapest and better control for active magnetic bearing can be achieved.

**Keywords:** Active Magnetic Bearing (AMB), Pulse Width Modulation (PWM), Power amplifiers, PSIM

## 1 Introduction

Active Magnetic Bearing is contact less bearing, which use magnetic levitation to supports the loads. AMBs are an advanced technology, broadly used in growing industry and for the improvement of our existing technology [1]. The close loop system of AMB is shown in Fig. 1 which includes electromagnet with rotor, controller, sensor and power amplifier.

In AMB, when gravitational force is equal to the electromagnetic force the rotor is levitated. Rotor position is sensed by the position sensor and sends the signal to the controller. The control signals are processed in a controller. The control signals are fed to power amplifier to control the current flowing through electromagnet, in such a way that a rotor keeps in hovering position [2, 3, 4].

The electrical equation of AMB system as shown in

Fig. 2 can be written as:

$$v(t) = Ri(t) + \frac{d}{dt}[L(x)i(t)] \quad (1)$$

Using Newton 2nd law of motion, the mechanical equation of AMB system can be written as

$$F = m \cdot g - c\left[\frac{\dot{x}}{x}\right]^2 \quad (2)$$

To meet the attractive force demand, the current flowing through the coil should be accurately controlled. For this reason, a number of power amplifiers are proposed for Maglev system, which includes solid state amplifiers as well as magnetic amplifiers. Switch mode and linear type solid state power amplifiers are used for low power applications. The efficiency of switch mode DC to DC amplifier is about 70 to 90 percent. A MOSFET base power amplifier has much larger power handling capacity when operates in ON/OFF mode [5, 6, 7].

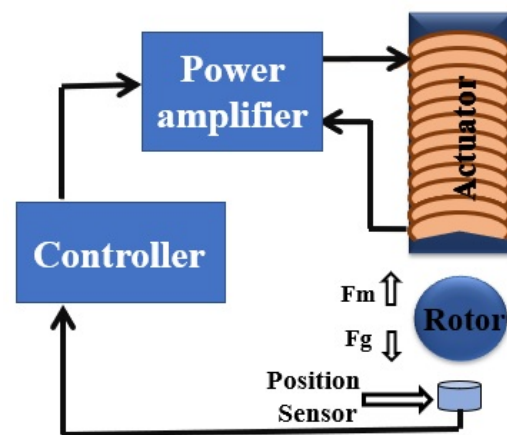

Figure 1: Block diagram of single axis AMB

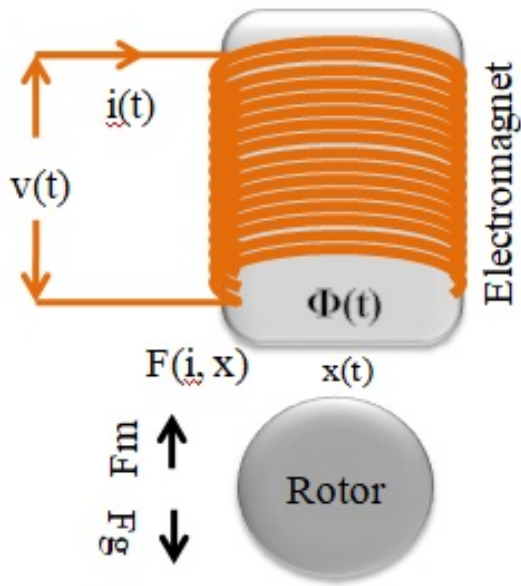

Figure 2: Simplified diagram of AMB system

## 2 Basic principle and operation of amplifiers

A buck amplifier is a DC-to-DC power amplifier which steps down voltage from its supply to its load. A simple Buck amplifier circuit as shown in Fig. 3. In this circuit when the switch is ON, supply voltage is connected across the load, and when the switch is off, voltage across the load is zero. Here the average output voltage and current are positive and this amplifier operate in first quadrant.

The average output voltage of simple buck amplifier is given by:

$$\frac{v_0}{v_i} = \frac{T_{on}}{T_{on} + T_{off}} = \frac{T_{on}}{T} = D \quad (3)$$

Where,  $T$  - total period -  $\frac{1}{f_s}$ ,  $T_{on}$  - transistor on time,  $D$  - duty ratio.

$$v_0 = T_{on} f_s v_i \quad (4)$$

$$v_0 = D v_i \quad (5)$$

A single switch power amplifier is a modification of buck converter. In this type of converter, diode is connected in series with parallel R-C circuit as shown in Fig. 4. When switch is ON, voltage is applied across the load and when the switch is in OFF position due

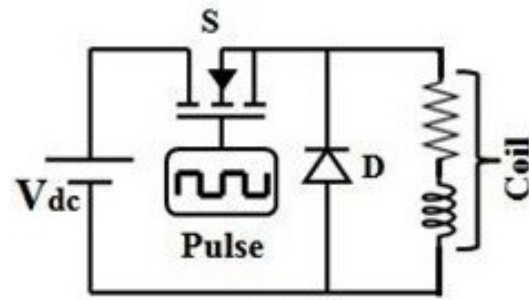

Figure 3: Schematic diagram of Buck Amplifier

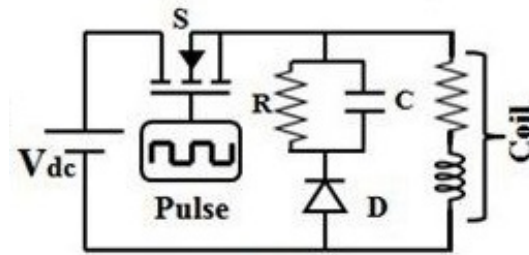

Figure 4: Schematic diagram of Single Switch Amplifier

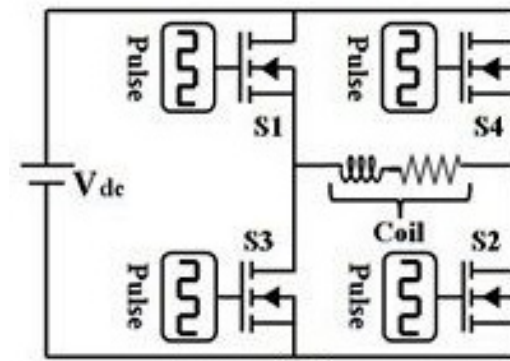

Figure 5: Schematic diagram of Full Bridge Amplifier

to parallel R-C network negative voltage is applied across the load. Positive and negative voltage can be achieved using this amplifier [8, 9, 10].

In case of full bridge amplifier as shown in Fig. 5, when both the switch S1 and S2 are triggered, the output current flows through the load and when both the other switch S3 and S4 are triggered the load current continues to flow. In this type of amplifier equal amount of positive and negative voltage is obtained using full bridge amplifier with four controlled switches which allowed coil current to be bi-directional. However, electromagnetic attraction force is independent of the coil-current direction [11].

The output equation of single switch amplifier and full bridge amplifier is shown in Eq. 3 [12, 13, 14, 15].

### 3 Pulse width modulation for power amplifier

PWM is used to trigger the switches in the amplifier circuit. The use of pulse width modulation has the advantage in that the power loss in the switching transistor is small because the transistor is either fully “ON” or fully “OFF”. As a result, the switching transistor has a much-reduced power dissipation giving it a linear type of control which results in better. Schematic diagram of PWM shown in Fig. 6.

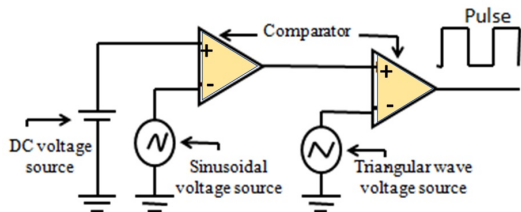

Figure 6: Generation of Pulse Width Modulation for power amplifier

By turning the switch between the load and supply the current and voltage across the load is controlled. If the on-time period of PWM is more as compared to off time period power supply to the load is higher.

### 4 Simulation

In this paper MULTISM software is used for simulating AC to DC converter and Pulse generating circuit. The whole simulation circuit consists of AC to DC converter which converts 230V AC to 15V DC, PWM circuit using 555 timer IC is used for triggering the switch and a single switch converter using MOSFET. Using this converter both the positive and negative output is obtained.

Simulation circuit of AC to DC converter is shown in Fig. 7 and V1 and V2 are the input ac supply. D1, D2, D3 and D4 are the rectifying diodes, C1, C2, C3 and C4 are the capacitors used for filtering or smoothing the output voltage. U1 and U2 are the positive and negative voltage regulator. This circuit is used for supplying a required dc voltage for the whole circuit. The output waveform of ac to dc converter as shown in Fig. 8. Channel\_A represent positive output dc voltage and channel\_B represents negative output voltage.

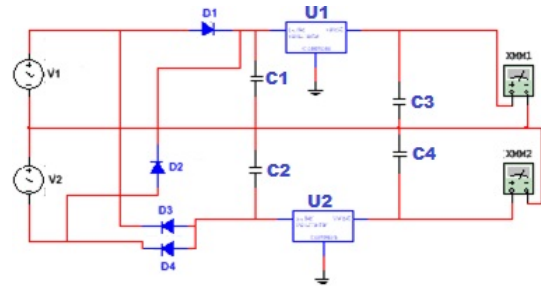

Figure 7: Circuit diagram of AC to DC converter

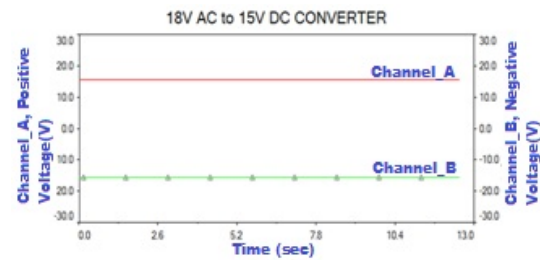

Figure 8: Simulation output of AC to DC converter

Pulse generating circuit and output waveform is shown in Fig. 9 and Fig. 10. By changing the variable resistance R3 and R4 duty cycle can be varied.

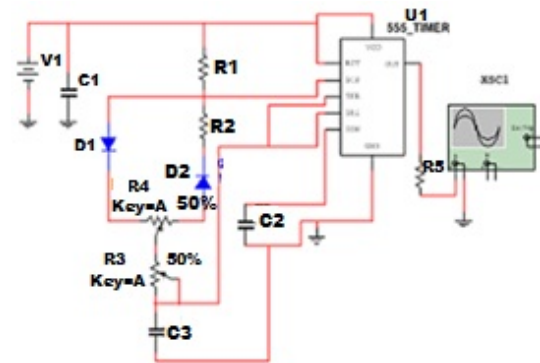

Figure 9: Circuit diagram of PWM Circuit using 555 Timer

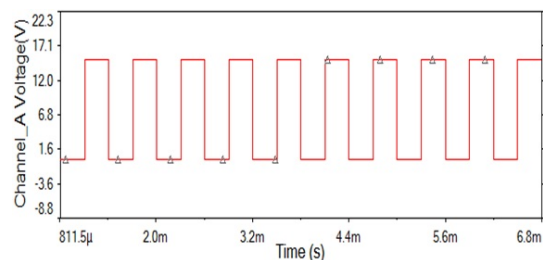

Figure 10: Simulation Output of PWM Circuit using 555 Timer

Buck amplifier, single switch amplifier and full bridge amplifier are simulated in PSIM software. Fig. 11 shows the circuit diagram of buck amplifier, output voltage and output current is shown in Fig. 12.

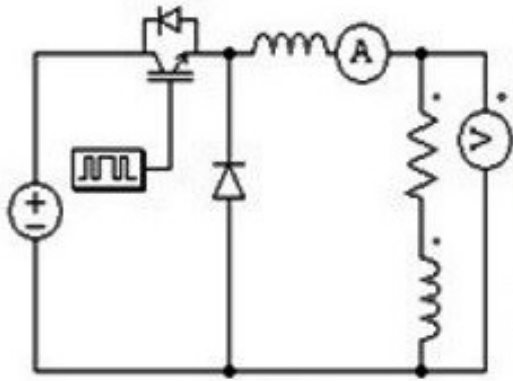

Figure 11: Circuit diagram of Buck amplifier

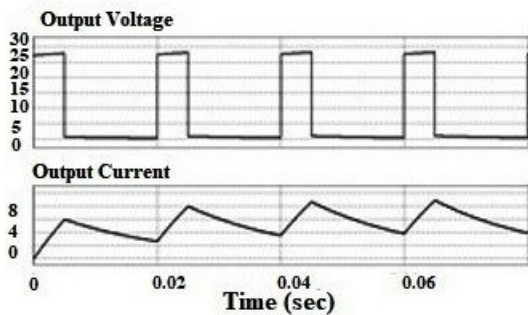

Figure 12: Output voltage and current waveform of buck amplifier

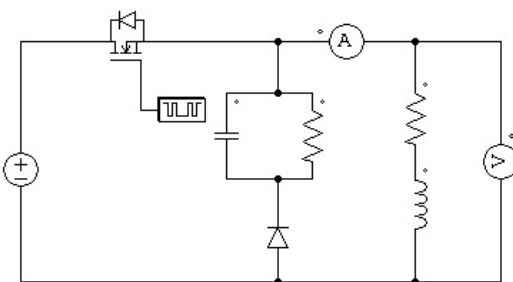

Figure 13: Circuit diagram of Single switch amplifier

Single switch converter along with output waveform is shown in Fig. 13 and Fig. 14. Full bridge amplifier circuit is shown in Fig. 15 and output voltage and output current is shown in Fig. 16.

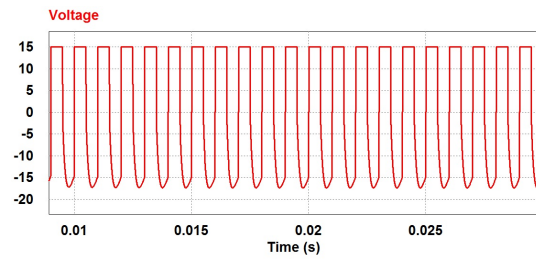

Figure 14: Simulation Output of Single Switch amplifier

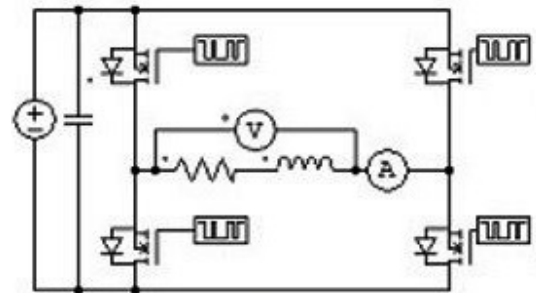

Figure 15: Circuit diagram of Full bridge amplifier

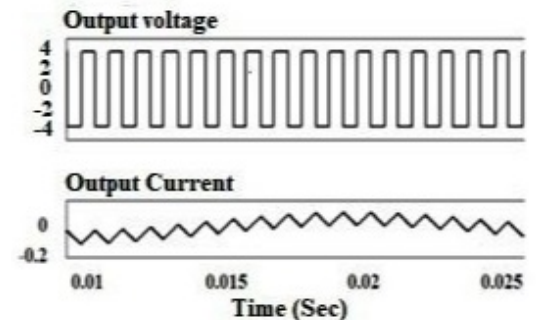

Figure 16: Output wave form of full bridge amplifier

After comparing all the outputs of these three amplifiers it is observed that single switch amplifier and full-bridge amplifier is giving a positive and negative output voltage which is advantages for AMB system. From these two amplifiers, single switch amplifier is cheaper and simple in design, that's why we choose this one for the proposed AMB system and implemented in hardware.

## 5 Hardware design

For the validation of the simulation results, hardware model is implemented based on the simulation. The value of components used in hardware model is same with the components used in simulation. In AC to

DC converter, step-down transformer is used, positive and negative voltage regulation is used for obtaining a desired dc voltage. Designed AC to DC converter is used for supply the required DC voltage to whole circuit.

Hardware circuit of AC to DC converter is shown in Fig. 17 and the output waveform is shown in Fig. 18 where channel A is the +15V dc output and channel B shows the -15V DC output.

Hardware model of pulse generating circuit using 555 timer is shown in Fig. 19, in this circuit duty cycle is varied from 0 to 100 percent as per requirement. The waveform is shown in Fig. 20 and Fig. 21 with different duty cycle.

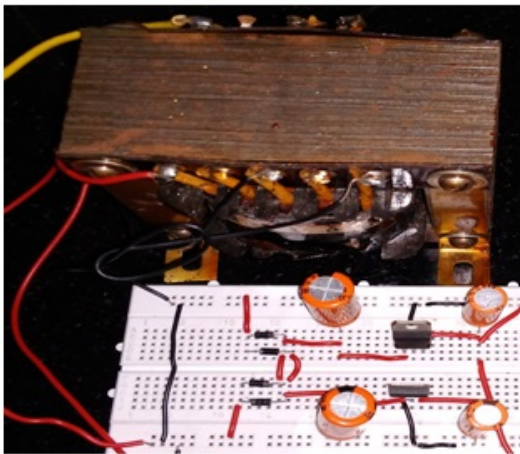

Figure 17: Hardware circuit of AC to DC converter



Figure 18: output waveform of AC to DC converter

Single switch converter is design using MOSFET. Here we get both the positive and negative output voltages using a single switch. The hardware model is shown in Fig. 22. Here gate pulse generated by pulse generating circuit is shown in Fig. 23 channel A and the output

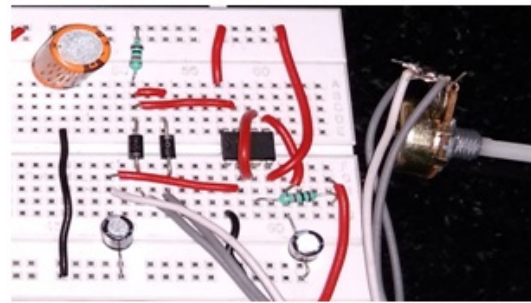

Figure 19: Hardware model of pulse generating circuit using 555 timer



Figure 20: This is a PWM output waveform with different duty cycle caption

waveform of converter is shown in Fig. 23 channel B.



Figure 21: PWM output waveform with different duty cycle

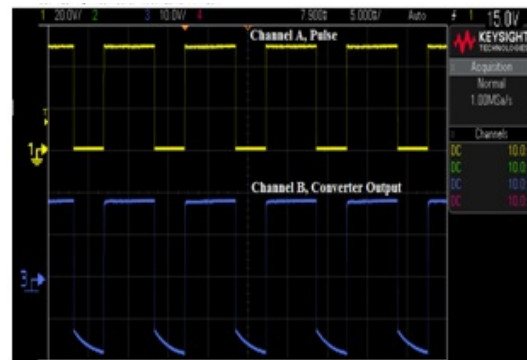

Figure 23: Output waveform of gate pulse and single switch converter

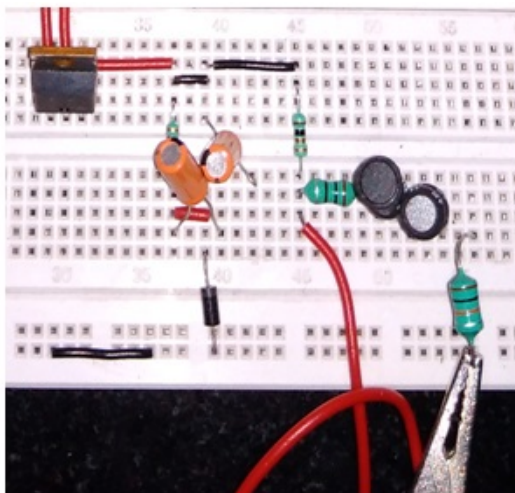

Figure 22: Hardware circuit of single switch converter

## 6 Conclusion

In this paper different Converters or Power amplifiers are analysed and simulated for controlling an Active Magnetic Bearing. Here different amplifiers are simulated and different results are shown. In buck amplifier, only unipolar voltage is applied to the magnetic coil, which is not suitable for AMB system. Bipolar voltage is obtained using full bridge and single switch amplifiers which are suitable for AMB system. Among the two amplifiers Single Switch Amplifier is implemented in hardware for the validation of simulation result. In the hardware result positive and negative output is achieved, which is similar to the simulation result.

## References

- [1] Sukanta Debnath and Pabitra Kumar Biswas. Design analysis, and testing of I-type electromagnetic actuator used in single-coil active magnetic bearing. *Electrical Engineering*, jul 2020.
- [2] S. J. Chapman. *Electric Machinery Fundamentals*. New York: WCB / McGraw-Hill, 1998.
- [3] P.S. Bimbhra. *Electrical Machinery*. New Delhi, Khanna Publishers, 2009.
- [4] B.K. Bose. Power electronics and drives-technology advances and trends. In *ISIE '99. Proceedings of the IEEE International Symposium on Industrial Electronics (Cat. No.99TH8465)*. IEEE.
- [5] R. Krishnan. *electric motor drives modeling, analysis, and control*. Prentice Hall, 2001.
- [6] G.K. Dubey. *Fundamentals of Electrical Drives*. New Delhi, Narosa Publishing House, 2009.
- [7] T.M. Undeland N. Mohan. *Power Electronics, Converters, Applications and Design*. John Wiley & Sons, 1995.
- [8] S.N.Manias. *Power Electronics*. Simeon Publications, 2012.
- [9] Gopakumar, K., "Power Electronics and Electrical Drives", Video Lectures 1-25, Centre for Electronics and Technology, Indian Institute of Science, Bangalore.
- [10] P.S. Bimbhra. *Power Electronics*. New Delhi, Khanna Publishers, 2006.
- [11] Sukanta Debnath, Pabitra Kumar Biswas, and Jonathan Laldinglana. Analysis and simulation of PWM based power amplifier for single axis Active Magnetic Bearing (AMB). In *2017 IEEE Transportation Electrification Conference (ITEC-India)*. IEEE, dec 2017.
- [12] M.H. Rashid. *Power Electronics*. Prentice Hall of India, New Delhi, 1993.
- [13] SIMULINK, "Model-based and system-based design using Simulink", Mathworks, Inc, Natick, MA, 2000.
- [14] MATLAB SIMULINK, version 2009, Sim Power-System, One quadrant chopper DC drive.
- [15] U. Das S. Debnath, P. K. Biswas. Analysis and Simulation of Different Types of Power Amplifiers Used in Electromagnetic Levitation System. *Journal of Power Technologies*, 98, 2018.