

# Optimization of start-up conditions to reduce thermal loads in cooled components of a supercritical steam turbine

Wojciech Kosman\*

*Silesian University of Technology  
Konarskiego 18, 44-100 Gliwice, Poland*

## Abstract

The paper describes the analysis of a start-up process of supercritical steam turbines. The issue under investigation is the decrease of thermal loads due to the designs that are specific to this type of machine. The analysis focuses on the main components—the rotor and the inner casing which operate at the highest level of the thermal loads. The analysis involves determination of the temperature and the stress fields and behavior in response to transient loading (thermal elongations). The results obtained enable a comparison to be made of various cases of transient loading.

*Keywords:* Supercritical steam turbine, Transient, Start-up, Optimization

## 1. Introduction

The development of steam turbines in recent years led to the application of supercritical steam parameters. The first supercritical steam turbines operated at above critical pressure (22.06 MPa) but with the temperature of live steam only slightly above the level of conventional turbines: in the range of 540...560°C. Further development aimed to increase the temperature of the live and the reheat steam in order to improve the efficiency of power generation [1]. Current manufacturing technology [2] makes it possible to achieve 600°C for the live steam and 610°C for the reheat steam. Ongoing investigations [3] aim to increase the temperature up to 650/660°C with some projects attempting the 700/710°C level [4].

The main obstacles in the improvement of power generation efficiency are the prices and properties of the materials applied to steam turbines [5]. There are materials readily available for the much higher temperature levels that are used in the gas turbine industry. However, a steam turbine requires significantly more material able to oper-

ate at high temperature than does a gas turbine. Also the pressure levels in steam turbines are much greater.

The limitations lead to the application of designs that make it possible to the lower thermal loads in the components of supercritical steam turbines [6]. Some of the designs are adapted from gas turbines and they include thermal screens and cooling systems [7].

The first solution involves additional parts made of a material resistant to high temperatures that separate the main components (the rotor and the inner casing) from the main flow of steam. Although steam usually fills the space between a screen and the protected component, the flow at the shielded surface is at a much lower velocity and this results in less intensive heat transfer.

The cooling systems include a flow at a lower temperature than the main flow. The cooling arrangement may vary depending on the particular turbine. Examples are shown in Fig. 1. The first example presents a cooling flow (the dotted line in Fig. 1a) forced near the surface of the rotor. A small amount of the cooling steam flows into the labyrinth packing in the front part of the turbine while the vast fraction flows along the rotor and eventually mixes with the main flow. A combination of a cooling flow and thermal screens may extend the range of cooling in the first and second stage of the steam path. The cooling of

\*Corresponding author

Email address: wojciech.kosman@polsl.pl (Wojciech Kosman\*)

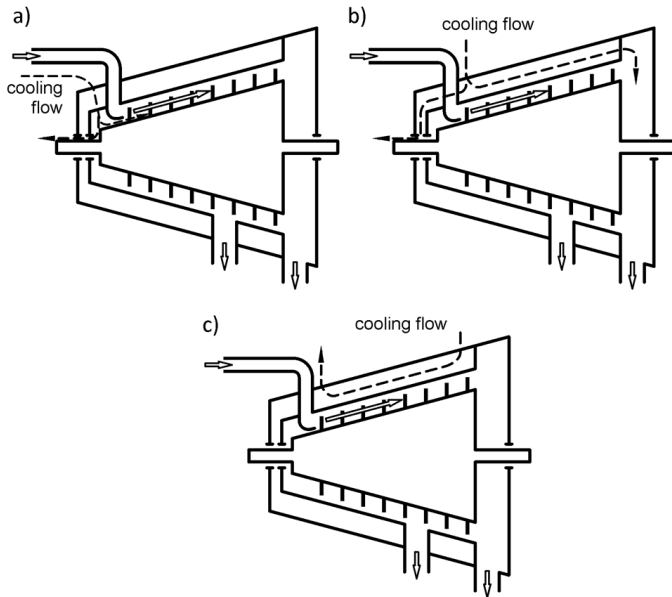

Figure 1: Arrangement of cooling flows

the casing is shown in Fig. 1b. The cooling steam enters the turbine near the live steam pipe and cools the live steam inlet section. It then flows through the area between the inner and the outer casing. It is worth noting that in steam turbines without a cooling system the area between the casing is filled with steam from the leakage through the front labyrinth packing. The temperature of that steam is usually very close to the temperature of the live steam. Thus the application of a cooling system changes the conditions of the heat transfer on the outer surface of the inner casing and on the inner surface of the outer casing.

Another cooling system design is shown in Fig. 1c. The cooling steam is injected into the area between the casings but in the opposite direction in the main steam path in the turbine. In this arrangement the flow between the casing cools the lower temperature sections and then the higher temperature sections.

The cooling system makes it possible to adjust, at least to some extent, the intensiveness of the heat transfer on chosen surfaces. This is especially important in transient states of operation because that is when stress reaches the highest level. The aims of the study described here are (i) to determine the potential range of adjustment, and (ii) determine whether optimization of the thermal state is possible. The investigations are presented for a start-up process, which is the commonest transient state and very demanding in terms of the stresses.

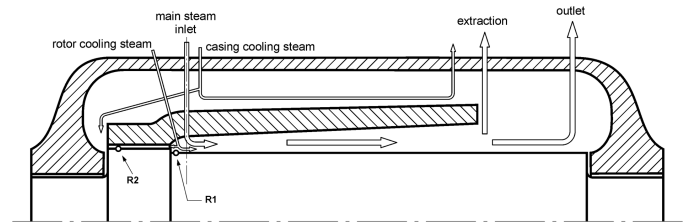

Figure 2: Steam turbine and the steam flows

## 2. Methodology

The research described here focuses on the thermal and strength state of a supercritical steam turbine during start-up. The investigation regards the main components: the rotor, the inner and the outer casings. Generally, the distributions of temperature and stresses in the components depend on:

- the geometry of the machine,
- the pressure and temperature of the steam at the inlet of the turbine,
- the temperature and amount of cooling steam,
- the start-up process.

All the calculations presented here were performed for a generic geometry of part of a steam turbine. It is shown in Fig. 2 together with the steam flows taken into consideration. The turbine is a reaction-type with one uncontrolled steam extraction. As written above the analysis involves the three main components. The inner casing is attached to the outer casing in the cross-section of the steam inlet, thus its fixed point moves when the outer casing expands due to the increasing temperature.

The main source of the high temperature in the components and the resulting stress is the main flow of the steam. Constant values of the inlet steam parameters in the full load operation are assumed at the levels of 650°C and 30 MPa. These values correspond to projects that are currently under development [1]. The temperature and pressure of the steam change along the steam path. Their values are calculated according to the expansion process in the consecutive stages.

Two other flows of the steam are considered in the investigated turbine. The first one is the rotor cooling steam (Fig. 2). This flow is delivered into the inlet section of the turbine at a pressure higher than the pressure of the inlet steam. The source of the flow depends on the part of the turbine. For a high pressure part this flow is extracted from between the stages of the superheater in

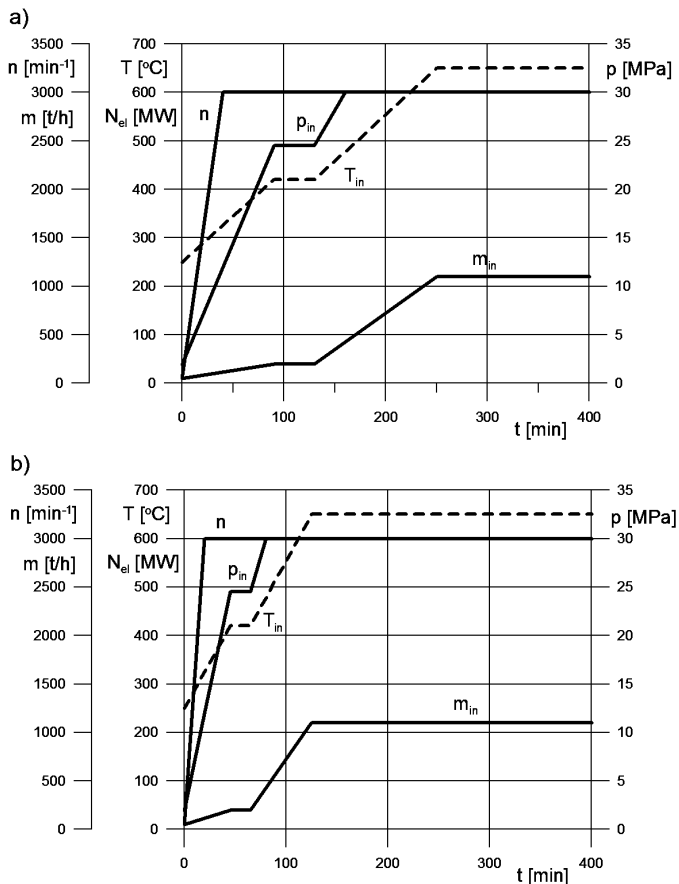

Figure 3: The start-up curves: standard (a) and shortened (b)

a steam boiler, while for an intermediate pressure turbine it may be taken from an HP part extraction. Three cases are investigated that differ in the area being cooled:

- case #1: the steam inlet section only,
- case #2: the steam inlet section and the first stage,
- case #3: the steam inlet section and the first two stages.

The other flow is the casing cooling steam. It enters the turbine near the main steam inlet and flow between the inner and the outer casing (Fig. 2). This flow changes the heat transfer conditions at the outer surface of the inner casing.

Both of the cooling flows are analyzed in the temperature range of 450...550°C in full load operation. This is about 70...85% of the inlet steam temperature.

The change of the steam parameters during a start-up process is described with the curves shown in Fig. 3. The first graph (Fig. 3a) corresponds to a standard start-up from a cold state, when the turbine has not operated for at least 50 hours prior to the start-up. The other graph

is a shortened start-up for the fast loading. In the research a two times faster start-up is investigated.

A shortened start-up may be applied only after detailed analysis of the strength conditions, as it always results in much higher levels of stress. A start-up two times faster than standard is an extreme case, usually applicable to a turbine after a short gap between operating cycles (less than 50 hours). However it allows us to compare different start-up conditions in detail because of the higher differences between the maximum values of stress. That is why it is included in the analysis shown here.

The start-up process was simulated using a numerical code based on the finite element method. The boundary conditions were applied according to the start-up curves and the calculation of the expansion process in the steam path and in the labyrinth packings. The calculations involved the following steps:

- modeling of the expansion process
- modeling of the flow through the labyrinth seals
- creating the boundary conditions for the FEM based on the results from the previous steps
- FEM calculations of the temperature field,
- FEM calculations of the displacements,
- FEM calculations of the stress field.

The FEM calculations are performed for the three main components separately and then compared in order to determine the relative elongations.

### 3. Reference start-up

In order to compare the various cases investigated here a reference case is provided. The case corresponds to a turbine with no cooling system and no additional flow between the inner and the outer casing. Therefore it represents the most extreme situation in terms of the temperature: the main components are exposed to steam at the highest possible temperature with no protection.

The stress levels for the reference start-up are shown in Fig. 4a. There are four characteristic values for stress: in the inner casing (IC), the outer casing (OC) and the rotor (R1 and R2, shown in Fig. 2). The stresses are given for the points of the components where the stress reaches the highest value during the whole start-up. These points were determined during the preliminary calculations.

Two characteristic points are chosen for the rotor. In the reference start-up the highest stress occurred at point

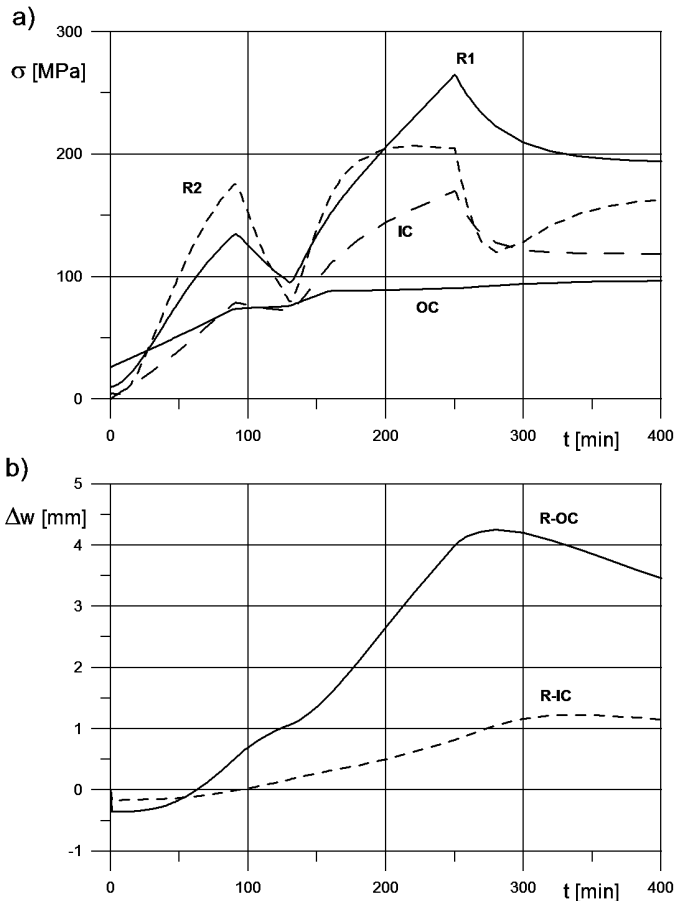

Figure 4: Stress (a) and thermal expansion (b) in the reference start-up

R1. However in other cases higher stress occurred at point R2.

The highest stress occurs in the rotor in the 250<sup>th</sup> minute of the start-up. This is when the live steam temperature becomes stable and the stress reaches its peak value before stabilizing. The stress level in the casing is noticeably lower. It is worth noting that there is no peak in the line for the outer casing—the stress simply reaches its steady state value.

Fig. 4b presents the thermal expansion of the turbine during the start-up. Relative values are shown. The R-OC line is the difference between the positions of the end of the rotor and the end of the outer casing (on the right side in Fig. 2) expressed in millimeters. The R-IC is the same for the end of the inner casing and the matching location on the rotor. The shape of the lines suggests that the expansion is not stabilized within the analyzed period of 400 minutes. Also some inertia may be observed when comparing Figs 4a and 4b.

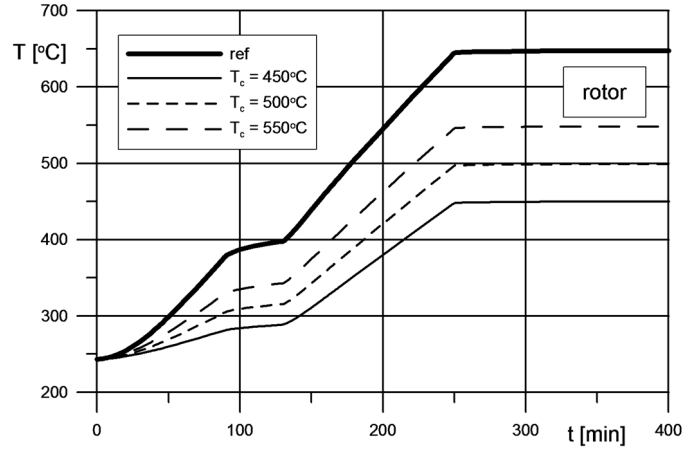

Figure 5: Temperature in the rotor

#### 4. Cooled rotor

The effect of the cooling is visible in Fig. 5. The graph in the figure compares the temperature of the rotor near the inlet of the steam for different temperature values of the cooling flow. The reference case is also added to the graph. Since the rotor is exposed to a cooling flow rather than the main flow its temperature changes according to the temperature of the simulated cooling steam.

Fig. 5 may be misleading as it refers to the temperature near the inlet. The effect of the cooling is further explained in Fig. 6. This figure shows the distribution of the temperature on the surface of the rotor along its axis. Two comparisons are presented. In the first one (Fig. 6a) the lines refer to the different values of the cooling temperature for case #2 described earlier. It may be observed that cooling lowers the temperature of the rotor within a certain range. The location of the maximum temperature is shifted downstream but the maximum value is almost independent of the cooling temperature. This is because the amount of the cooling flow is much lower than the amount of the main steam and the mixing process between two streams is almost immediate with little change in the main stream temperature.

The second comparison (Fig. 6b) shows the distribution of rotor temperature at the surface for various cases of cooling. Here the differences between the maximum temperatures are larger. Also the location where the maximum temperature occurs is different.

Interestingly, in both of the comparisons the location of the maximum temperature is not the same as the location of the point where maximum stress occurs. This is either point R1 or R2. The corresponding graphs are presented in Fig. 7.

The peak stress value at the point R1 decreases for

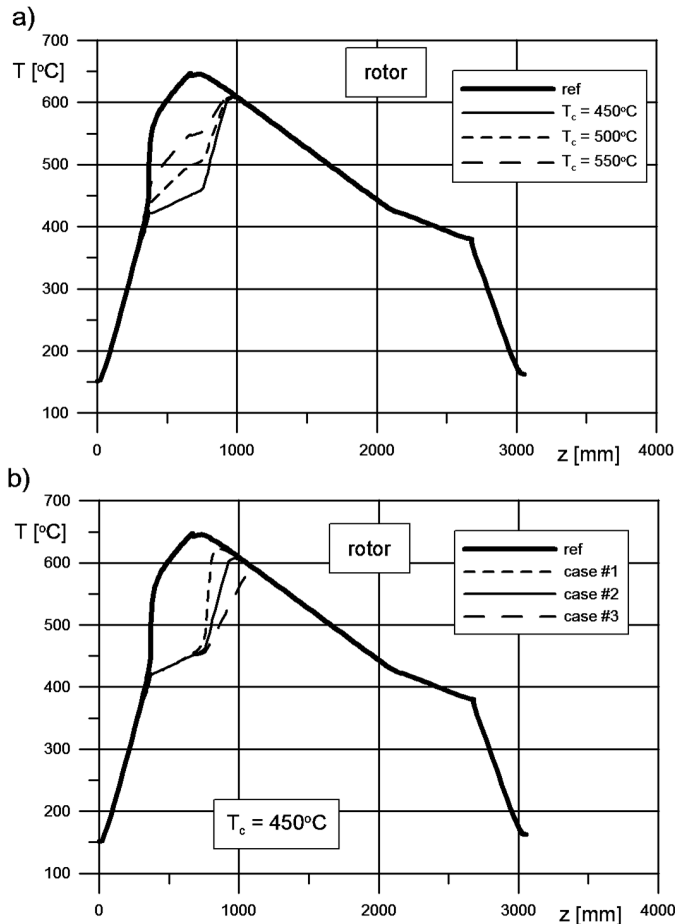

Figure 6: Rotor surface temperature for different cooling temperature (a) and range of cooling (b)

lower temperatures of the cooling flow. The decrease is not linear, which means that for a given design (the range of the cooling) there exists a limit level of the stress in the cooled sections of the rotor. The problem is that even though the stress in the inlet section decreases other parts of the rotor are still vulnerable to a high level of stress. This is evident in Fig. 7b, which shows the stress at point R2.

As mentioned before this point is located under the labyrinth packing in the front section of the rotor. The cooling flow does not affect this section much. A small amount of the cooling steam that flows through the packing lowers the stresses by approximately 7% but as the temperature of the cooling steam was lowered in the simulations the stress level even increased.

In other words the application of cooling to the turbine in the terms of stress is justified only up to the limit defined by the stress in the sections that are little affected by the cooling system.

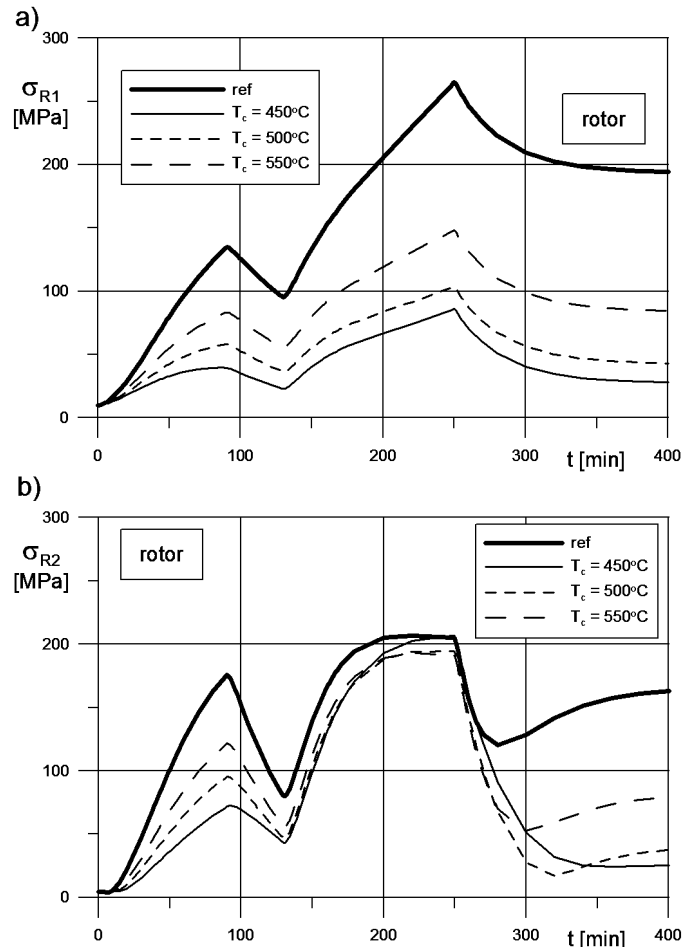

Figure 7: The stress at point R1 of the rotor

## 5. Cooled casings

Application of the cooling system to the inner casing does not cause the same noticeable decrease in stresses in respect of the rotor. A comparison of the stresses in the inner casing during start-up is shown in Fig. 8.

There is a difference of around 8% between the reference start-up and the casing cooled with steam at  $450^\circ\text{C}$  (the line marked as  $T_c = 450^\circ\text{C}$ ). The stress may be further reduced if the additional steam is forced into the area between the inner and the outer casing. The graph in Fig. 8 includes a line for the casing that is cooled from the inner side and the outer side simultaneously.

The cooling on the inner side includes only the sections of the casing that are located in its front part, in the front of the main steam inlet. There is no cooling of the nozzle blades in the first or second stage. This assumption corresponds to current trends in the design of modern steam turbines. Since the level of stresses is generally lower in casings than in rotors, manufactures do not provide extensive cooling systems for casings in the steam

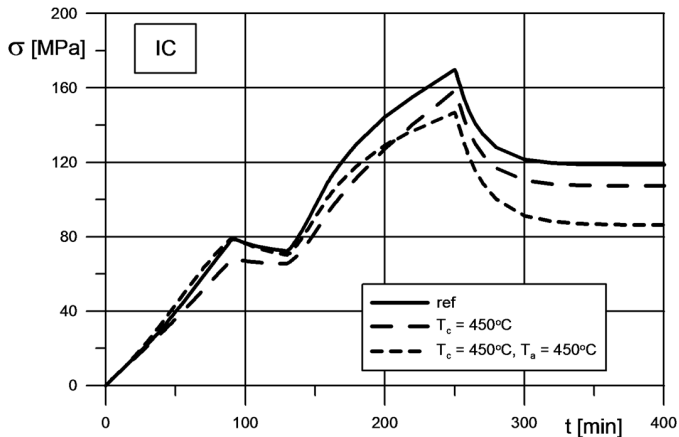

Figure 8: The stress in the inner casing

path and only the inlet section is cooled. Even with this restricted cooling, the effects are visible.

Nevertheless the additional steam between the casings does not affect solely the inner casing it cools the outer casing to a great degree too. In a turbine with no forced flow between the casings this area is filled with a steam at a relatively high temperature. The steam there comes mostly from the front labyrinth packing (a leakage) and from the steam extraction (a leakage as well). For a main steam temperature of  $650^{\circ}\text{C}$  the steam between the casings is in excess of  $550^{\circ}\text{C}$ . Forcing a flow of additional steam at a lower temperature always decreases the temperature of the outer casing. The maximum temperature of the steam to which the outer casing is exposed is the temperature of the additional steam (in the described research  $550\dots450^{\circ}\text{C}$ ).

## 6. Shortened start-up

The shortened start-up was analyzed—as described before—in order to verify the influence of the cooling system on the flexibility of the turbine. The results of the simulation are shown in Fig. 9 for the rotor.

The figure presents the stress in the characteristic points during the shortened start-up conducted according to the curves from Fig. 3b. As expected, the stress level is generally higher. Here the stress at point R2 is higher than at point R1. However, it is evident that in this case the application of cooling actually lowers the stress at both points. The differences between the lines for various cooling temperature are again smaller for point R2, but there is a major difference between the reference shortened start-up and a start-up with cooling.

Comparison of the results allows us to formulate the conclusion that the influence of the cooling systems is

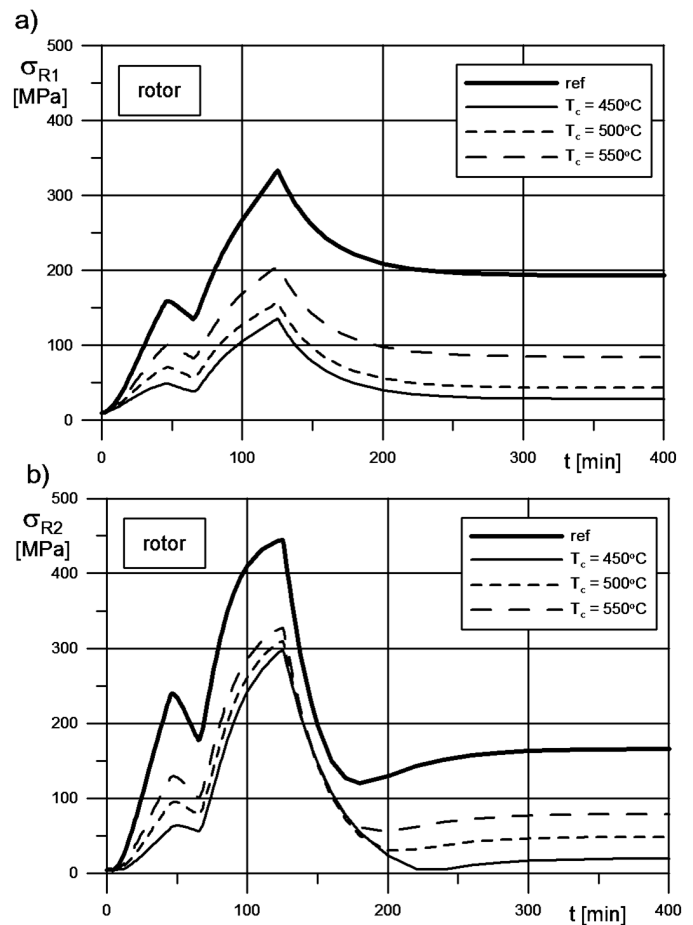

Figure 9: The stress in the rotor during a shortened start-up

more noticeable for the shortened start-up. In the examples shown in Fig. 9 the stress level at point R2 is decreased below 300 MPa and is not significantly above the value of 270 MPa, which is the maximum stress at point R1 for a standard start-up (see Fig. 7b and the peak value for the reference case). If the start-up is not that fast, the cooling flows may be adjusted to keep the stress level below an appropriate limit.

## 7. Summary

The results of the simulations presented here show that there is an area for optimization of the thermal conditions. A combination of the various arrangements of the cooling flows makes it possible to change the intensiveness of the heat transfer on the chosen surfaces. However, a simple application of cooling may not always produce the desired results, especially for the inner casing. Detailed analysis is always required for a specific design.

A very important issue is that in all cases that involved cooling, the maximum temperature of the components was

lowered when compared to the reference case (see for example Fig. 5 and 6). This is important because every material has two limitations in the range of the thermal and the strength behavior: the maximum allowable stress and the maximum allowable temperature. The materials investigated for use in the turbine branch are able to withstand higher stress than the materials used in older subcritical steam turbines. More often it is the temperature that defines the limit.

It should also be emphasized that the decrease in temperature and stress should be determined for a particular design—for a particular shape of a casing and a rotor. Here a generic geometry was used and that allowed us to evaluate the potential range of change in the thermal and strength states.

One should also remember that the start-ups investigated here were based on the ideal curves provided by the manufacturer. The boundary conditions for the simulations involved ideal changes of the main steam parameters and flow. During start-ups there are variations from the curves, which increases the stress. However, the maximum temperature is not affected.

## Acknowledgements

The results presented in this paper were obtained from research work co-financed by the National Center of Research and Development in the framework of Contract SP/E/1/67484/10—Strategic Research Programme—Advanced Technologies for Obtaining Energy: Development of a Technology for Highly Efficient Zero-emission Coal-fired Power Units Integrated with CO<sub>2</sub> Capture.

## References

- [1] R. Knodler, S. Straub, B. Scarlin, Komet 650—investigation of materials for use in steam turbines at temperatures up to 650 (degree) c, *VGB PowerTech* 88 (3) (2008) 59.
- [2] M. Susta, Latest development in supercritical steam technology, *PowerGen Asia* (2008) 21–23.
- [3] W. Kosman, Thermal analysis of cooled supercritical steam turbine components, *Energy* 35 (2) (2010) 1181–1187.
- [4] W. Kosman, The possibilities to reduce casing thermal loads of the supercritical steam turbines, *Archives of Thermodynamics* 30 (2009) 149–161.
- [5] F. Cziesla, H. Kremer, U. Much, J.-E. Riemschneider, R. Quinkertz, Advanced 800+ mw steam power plants and future ccs options, in: *COAL-GEN Europe 2009*, Katowice, Poland, 2009.
- [6] F. Cziesla, J. Bewerunge, A. Senzel, Lünen—state-of-the-art ultra supercritical steam power plant under construction, in: *POWER-GEN Europe*, 2009.
- [7] W. Kosman, The influence of external cooling system on the performance of supercritical steam turbine cycles, *Archives of Thermodynamics* 31 (3) (2010) 131–144.